

2PBM

Bent Axis Piston Motor

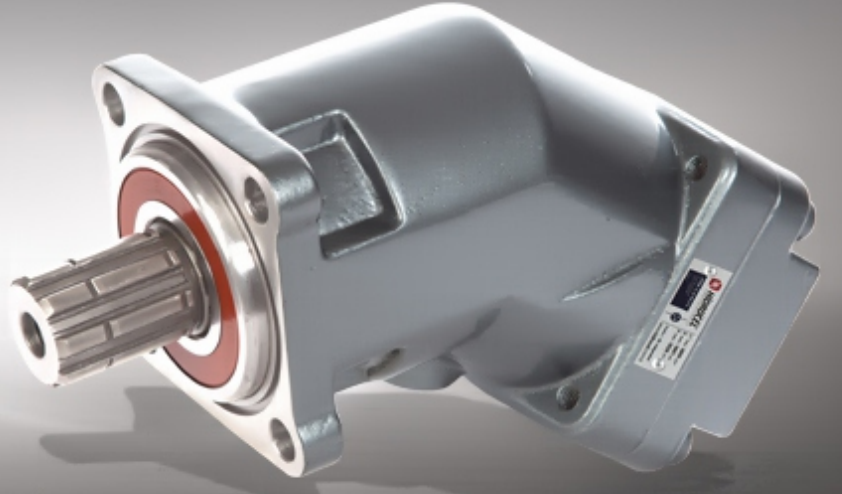

2PBM Motors have the following advantages ;

- Compact Design,
- Economical Conception,
- High Power Density,
- High Efficiency,
- High Rotating Speeds,
- From 5cc to 130cc,
- High Pressure,
- Good Starting Characteristics,
- Optimized Weight and Size,

Other Advantages of 2PBM

Interchangeable and Compatible with other DIN Bent Axis Motors,
Special Designed Pistons,
One-Piece Piston with Piston Rings,
For use in stationary and mobile applications,
Compact motor design and extra durable parts,
High Operational Reliability and High Starting Torque
Extra Warranty with Wide Service

40° bent axis design giving high power, small overall dimensions, optimum efficiency and economic design. Flange and shaft designed for direct mounting on the equipments. The fixed displacement bent axis motors generates a hydraulic fluid flow. It is designed for use in trucks, commercial vehicles, construction type equipments and all stationary hydraulic applications. The 2PBM is a motor with rotary group in bent-axis design. Flow is proportional to drive speed and displacement.

For axial piston units with bent-axis design, the Pistons are arranged diagonally with respect to the drive shaft. The motor covers the whole displacement range 5 to 130 cm³/rev. The motor has been developed with modern styling and design to satisfy market demand as to designed new generation plate, extra parts and pistons with give high flow performance, high pressures with high efficiency and very small dimensions.

The motor is available both to DIN and SAE world standards and can be mounted either directly at the gear box or via a drive shaft. Other brand bent axis motors compatible and interchangeable with 2PBM bent axis motors. Refer to the data sheet and order confirmation for the technical data, operating conditions and operating limits of the bent axis piston motors.

Ordering Code of 2PBM Motors

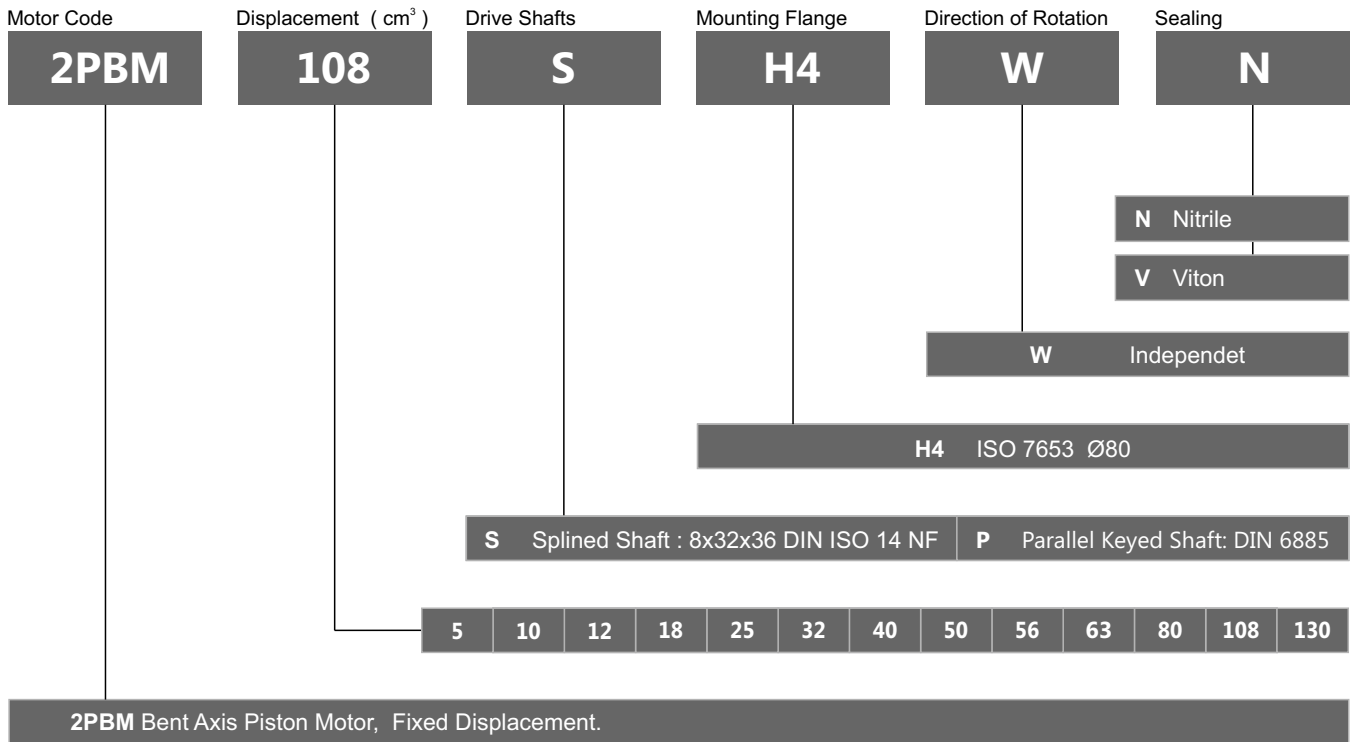

Formulas			
Pump Output Flow	GPM	$GPM = (\text{Speed (rpm)} \times \text{disp. (cu. in.)}) / 231$	$GPM = (n \times d) / 231$
Pump Input Horsepower	HP	$HP = GPM \times \text{Pressure (psi)} / 1714 \times \text{Efficiency}$	$HP = (Q \times P) / 1714 \times E$
Pump Efficiency	E	Overall Efficiency = Output HP / Input HP	$E_{\text{Overall}} = \text{HP}_{\text{Out}} / \text{HP}_{\text{In}} \times 100$
		Overall Efficiency = Volumetric Eff. × Mechanical Eff.	$E_{\text{Overall}} = \text{EffVol.} \times \text{EffMech.}$
Pump Volumetric Efficiency	E	Volumetric Efficiency = Actual Flow Rate Output (GPM) / Theoretical Flow Rate Output (GPM) × 100	$\text{EffVol.} = \text{Q}_{\text{Act.}} / \text{Q}_{\text{Theo.}} \times 100$
Pump Mechanical Efficiency	E	Mechanical Efficiency = Theoretical Torque to Drive / Actual Torque to Drive × 100	$\text{EffMech} = \text{T}_{\text{Theo.}} / \text{T}_{\text{Act.}} \times 100$
Pump Displacement	CIPR	$\text{Displcmnt (In.}^3 \text{ / rev.)} = \text{Flow Rate (GPM)} \times 231 / \text{Pump RPM}$	$\text{CIPR} = \text{GPM} \times 231 / \text{RPM}$
Pump Torque	T	Torque = Horsepower × 63025 / RPM	$T = 63025 \times \text{HP} / \text{RPM}$
		Torque = Pressure (PSIG) × Pump Displacement (CIPR) / 2π	$T = P \times \text{CIPR} / 6.28$

- Horsepower for driving a pump** : For every 1 hp of drive, the equivalent of 1 gpm @ 1500 psi can be produced.
- Horsepower for idling a pump** : To idle a pump when it is unloaded will require about 5% of it's full rated power
- Wattage for heating hydraulic oil** : Each watt will raise the temperature of 1 gallon of oil by 1° F. per hour.
- Flow velocity in hydraulic lines** : Pump suction lines 2 to 4 feet per second, pressure lines up to 500 psi - 10 to 15 ft./sec., pressure lines 500 to 3000 psi - 15 to 20 ft./sec.; all oil lines in air-over-oil systems; 4 ft./sec.

Technical Data II

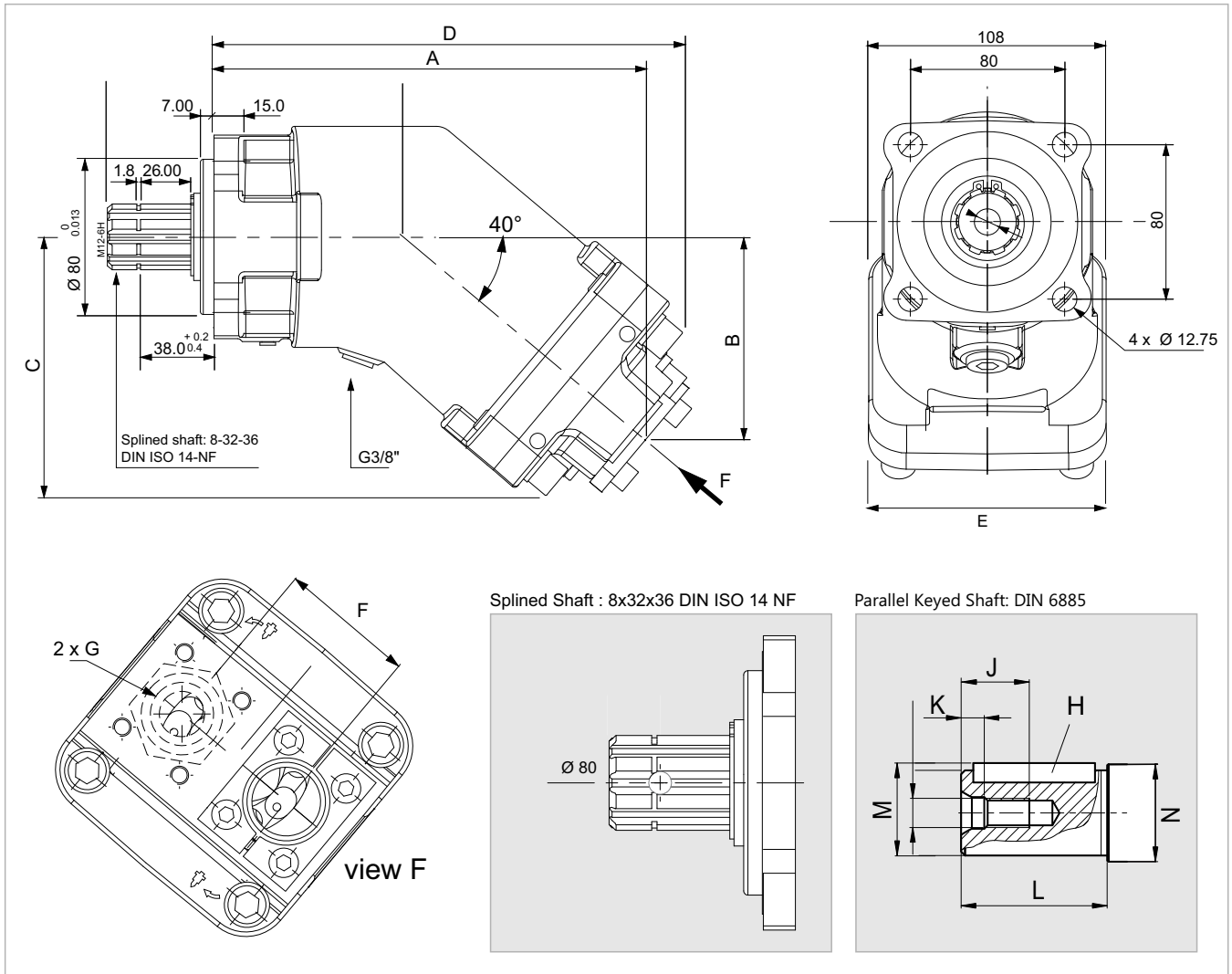

	5	10	12	18	25	32	40	50	56	63	80	108	130
cc	5,00	10,00	12,00	18,00	25,00	32,00	40,20	50,00	56,40	63,00	80,00	108,4	130,0
A	170,0	170,0	170,0	170,0	170,0	177,0	177,0	188,0	188,0	188,0	215,0	215,0	215,0
B	71,0	71,0	71,0	71,0	71,0	76,0	76,0	86,0	86,0	86,0	98,0	98,0	98,0
C	103,0	103,0	103,0	103,0	103,0	108,0	108,0	118,0	118,0	118,0	132,0	132,0	132,0
D	197,0	197,0	197,0	197,0	197,0	202,0	202,0	214,0	214,0	214,0	240,0	240,0	240,0
E	107,5	107,5	107,5	107,5	107,5	107,5	107,5	107,5	107,5	107,5	122,5	122,5	122,5
F	54,0	54,0	54,0	54,0	54,0	54,0	54,0	54,0	54,0	54,0	60,0	60,0	60,0
G	G 3/4"	G 3/4"	G 3/4"	G 3/4"	G 3/4"	G 3/4"	G 3/4"	G 3/4"	G 3/4"	G 3/4"	G 1"	G 1"	G 1"
H	6	6	6	8	8	10	10	10	10	10	12	12	12
J	16	16	16	22	22	28	28	28	28	28	28	28	28
K	5	5	5	7,5	7,5	9,5	9,5	9,5	9,5	9,5	9,5	9,5	9,5
L	40	40	40	50	50	60	60	60	60	60	70	80	70
M	22,5	22,5	22,5	33	33	38	38	38	38	38	38	43	38
N	Ø 28	Ø 28	Ø 28	Ø 35	Ø 35	Ø 35	Ø 35	Ø 40	Ø 40	Ø 40	Ø 45	Ø 50	Ø 45

Performance

Compare Table of Torque

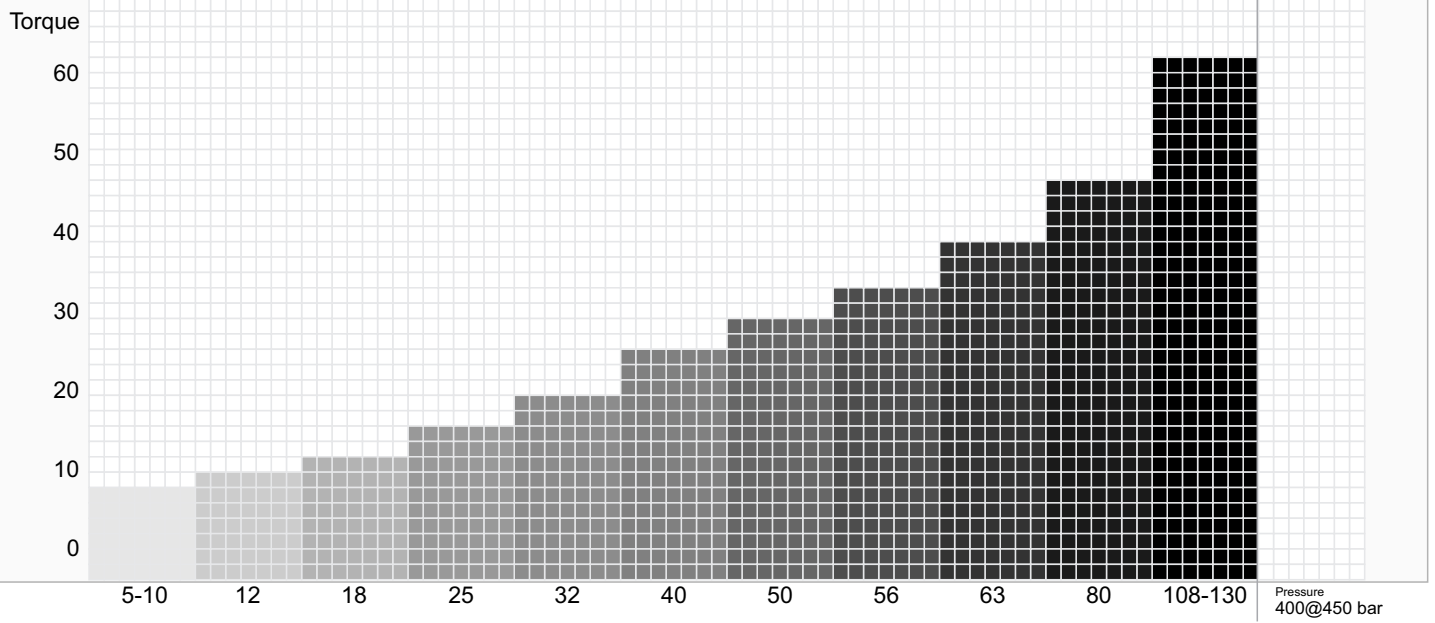

Efficiency of 2PBM Motors (1000 rpm)

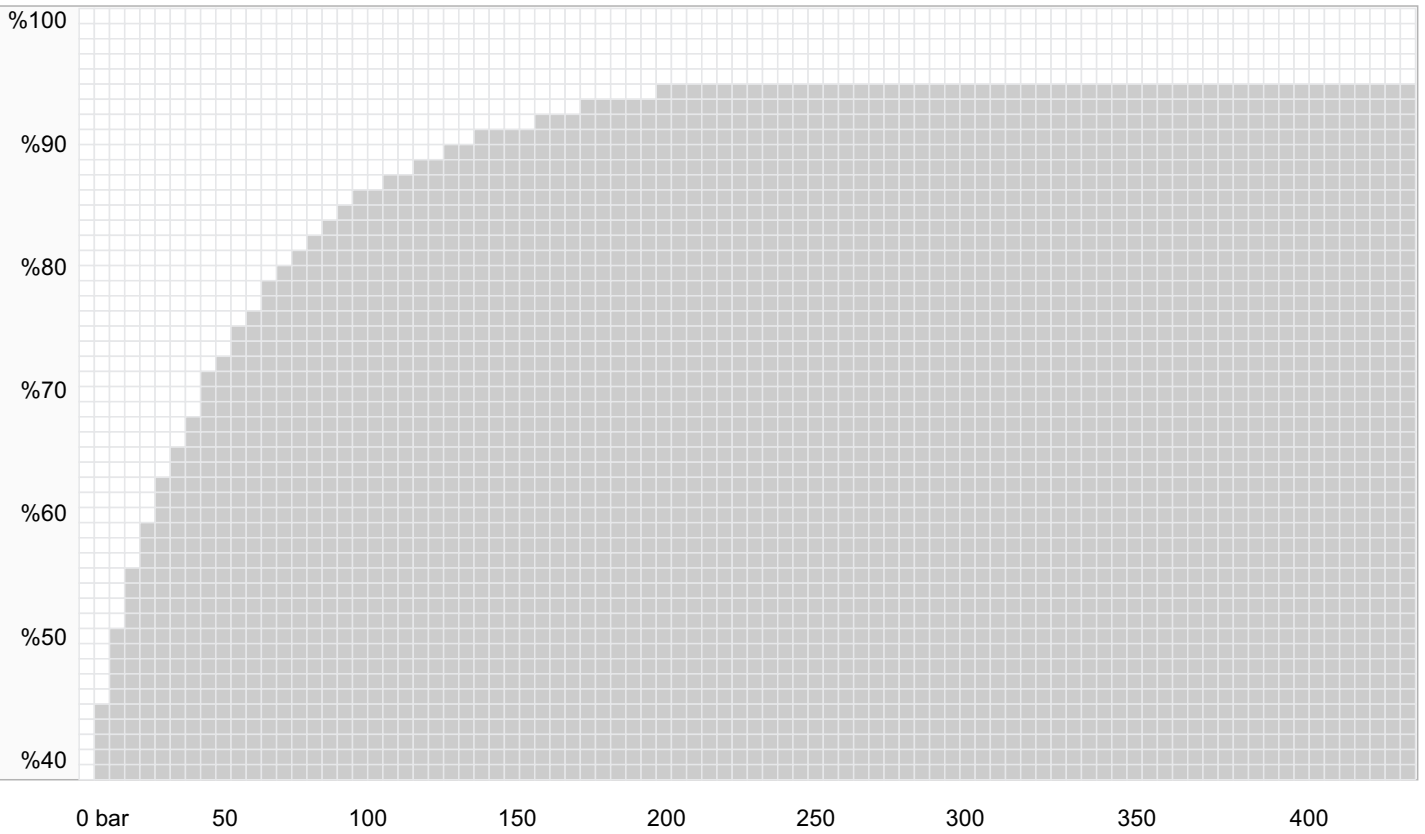

2PBM 5

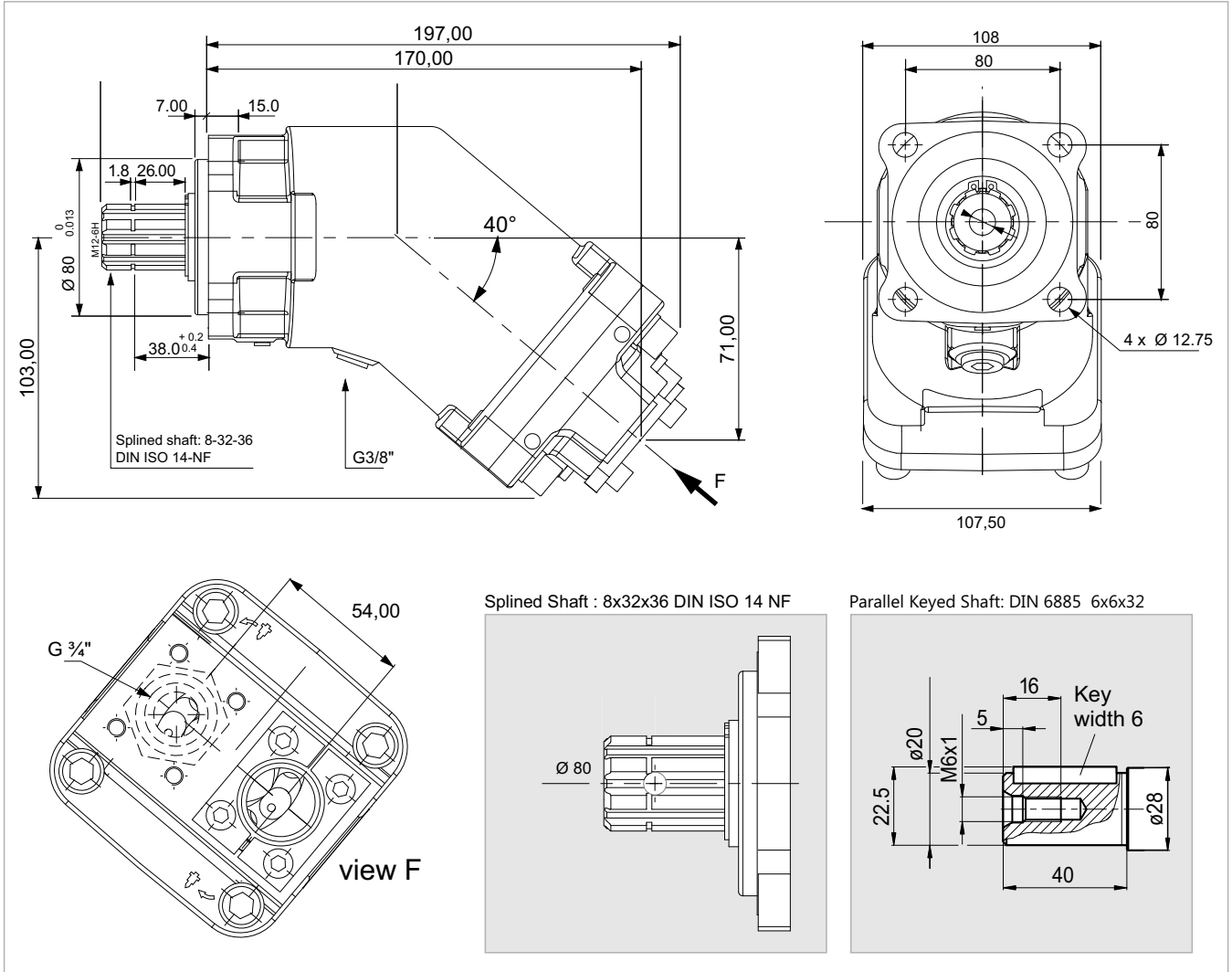

x 1000 rpm	5,00 cc
x 1500 rpm	7,50 cc
Max. Continuous Pump Speed	8800 rpm
Max. Intermittent Pump Speed	9400 rpm
Max. Continuous Pressure	400 bar
Max. Peak Pressure	450 bar
Torque bar	0.17 m.N/bar
Torque at 350 bar	62 m.N
Weight without accessories	9,00 kg
Weight with accessories	9,50 kg
Max. Motor Temperature	-25°
Min. Motor Temperature	110°

2PBM 10

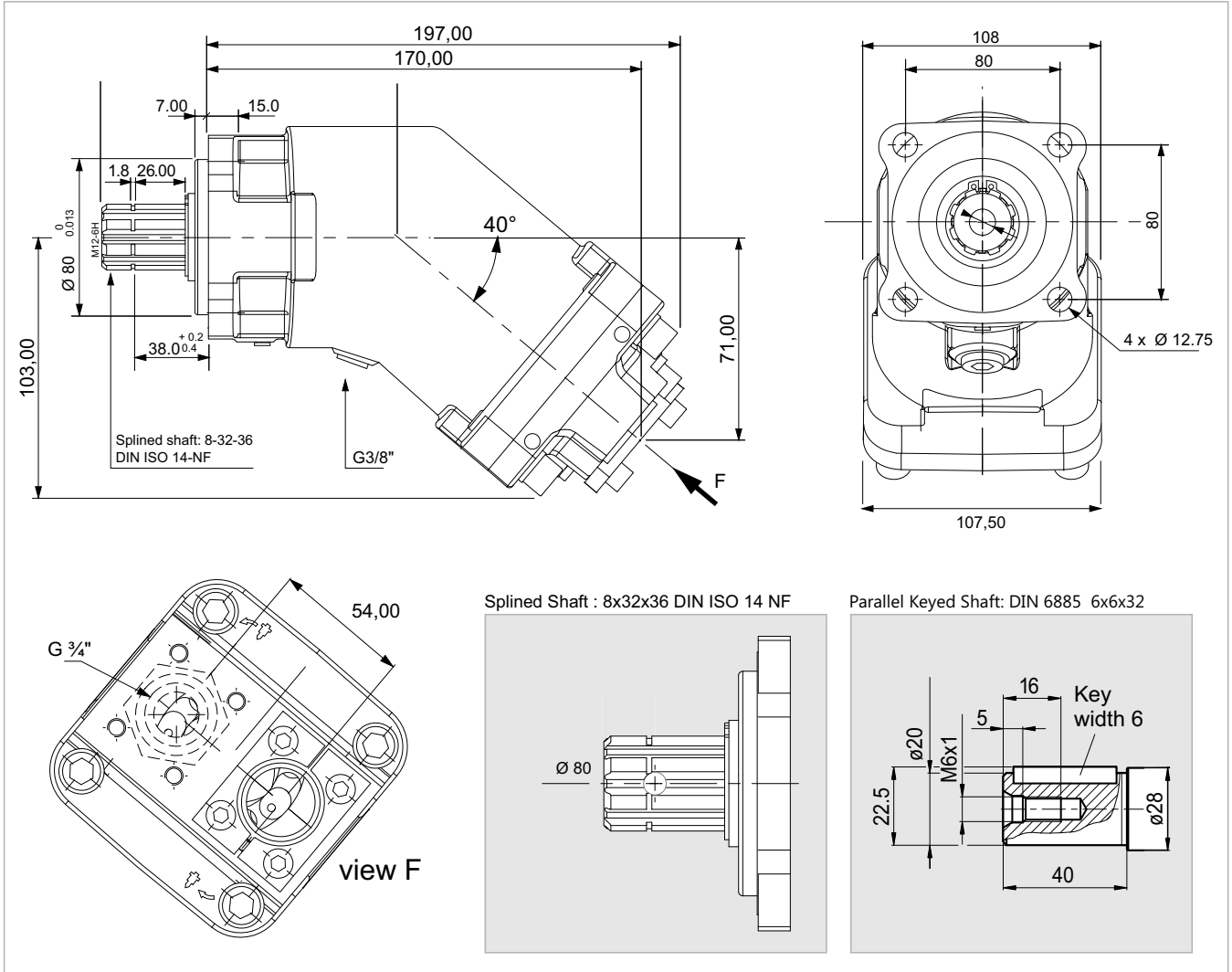

x 1000 rpm	10,00 cc
x 1500 rpm	15,00 cc
Max. Continuous Pump Speed	8000 rpm
Max. Intermittent Pump Speed	8800 rpm
Max. Continuous Pressure	400 bar
Max. Peak Pressure	450 bar
Torque bar	0.17 m.N/bar
Torque at 350 bar	64 m.N
Weight without accessories	9,00 kg
Weight with accessories	9,50 kg
Max. Motor Temperature	-25°
Min. Motor Temperature	110°

2PBM 12

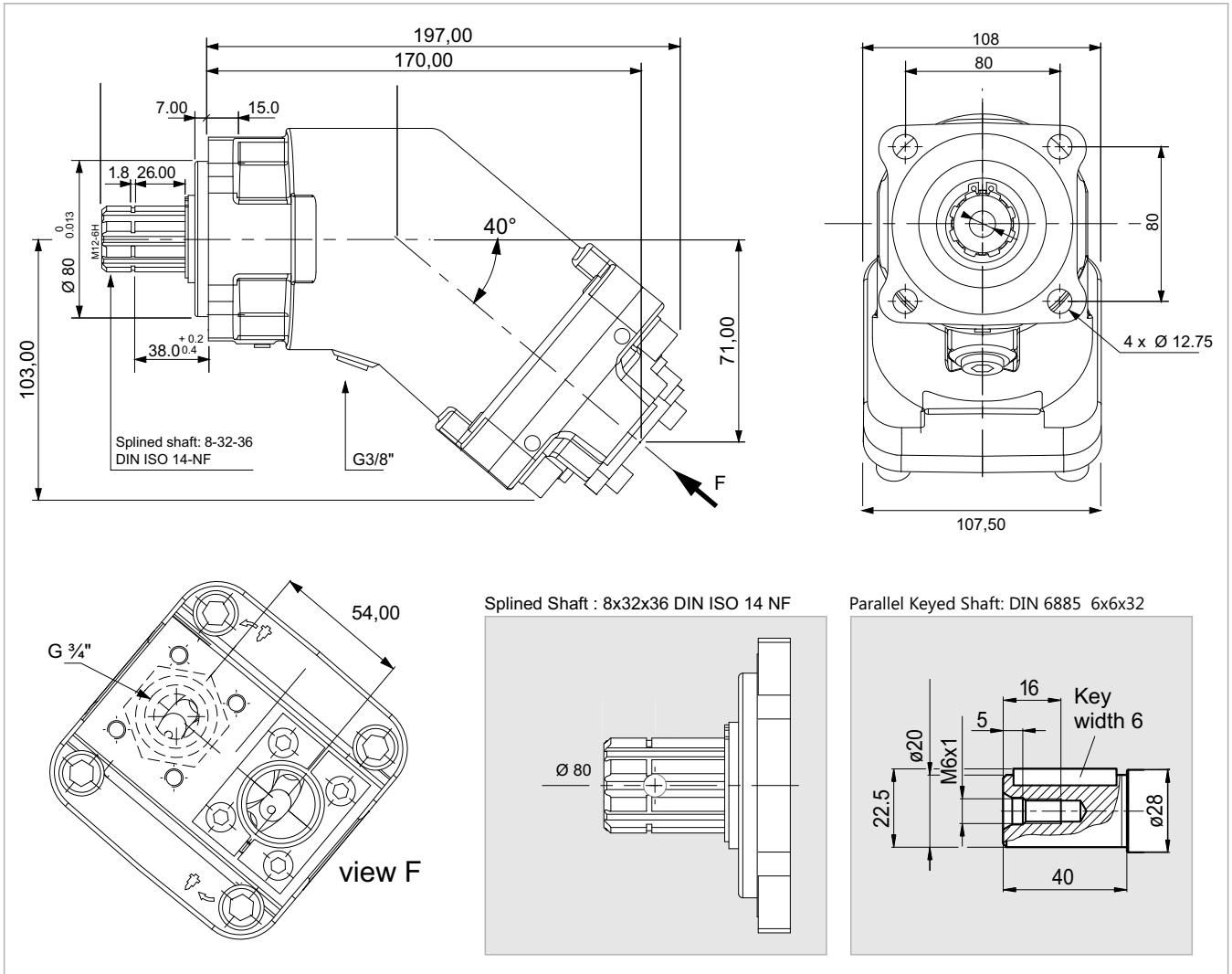

x 1000 rpm	12,00 cc
x 1500 rpm	18,00 cc
Max. Continuous Pump Speed	8000 rpm
Max. Intermittent Pump Speed	8800 rpm
Max. Continuous Pressure	400 bar
Max. Peak Pressure	450 bar
Torque bar	0.18 m.N/bar
Torque at 350 bar	66 m.N
Weight without accessories	9,00 kg
Weight with accessories	9,50 kg
Max. Motor Temperature	-25°
Min. Motor Temperature	110°

2PBM 18

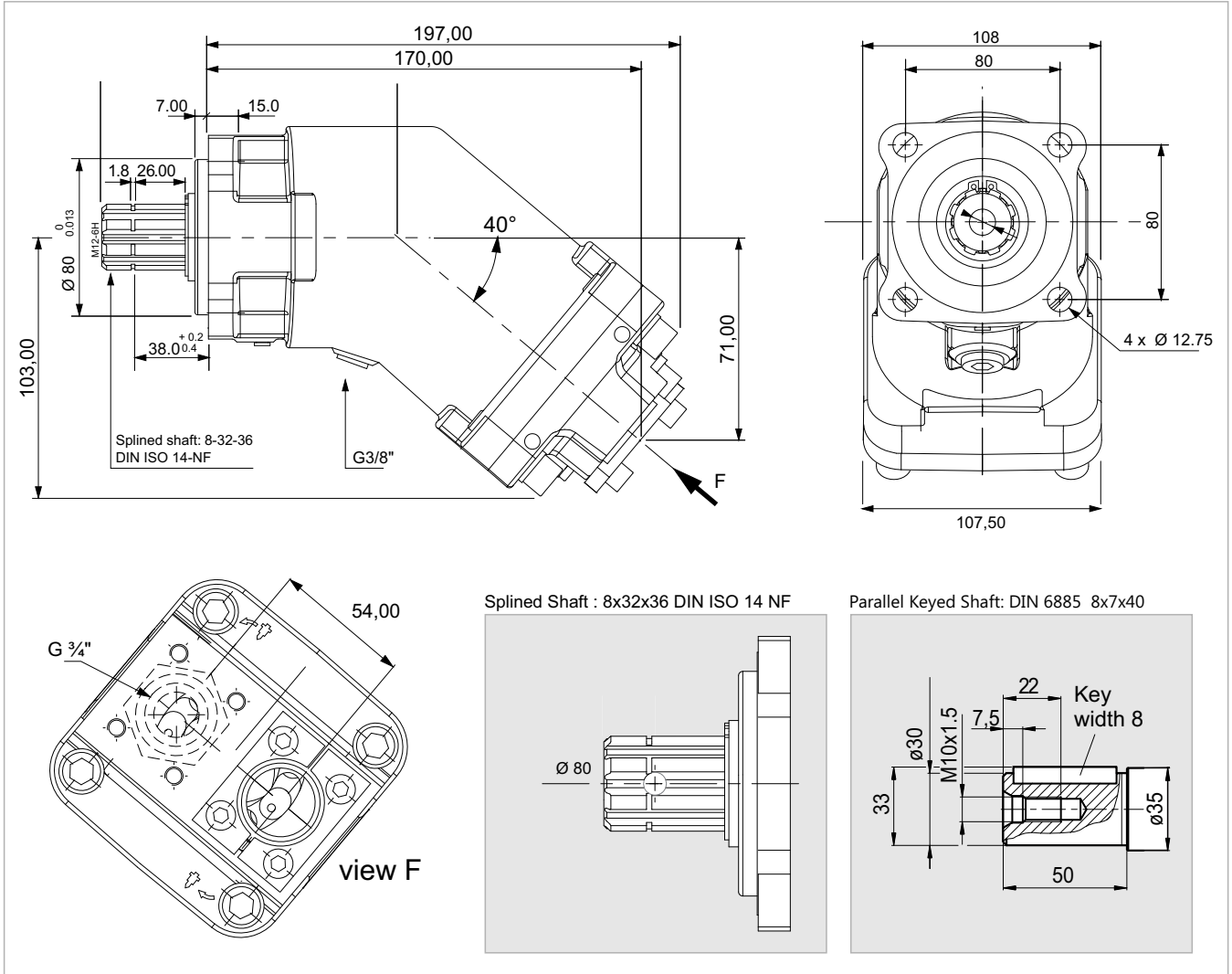

x 1000 rpm	18,00 cc
x 1500 rpm	27,00 cc
Max. Continuous Pump Speed	8000 rpm
Max. Intermittent Pump Speed	8800 rpm
Max. Continuous Pressure	400 bar
Max. Peak Pressure	450 bar
Torque bar	0.28 m.N/bar
Torque at 350 bar	98 m.N
Weight without accessories	10,00 kg
Weight with accessories	10,50 kg
Max. Motor Temperature	-25°
Min. Motor Temperature	110°

2PBM 25

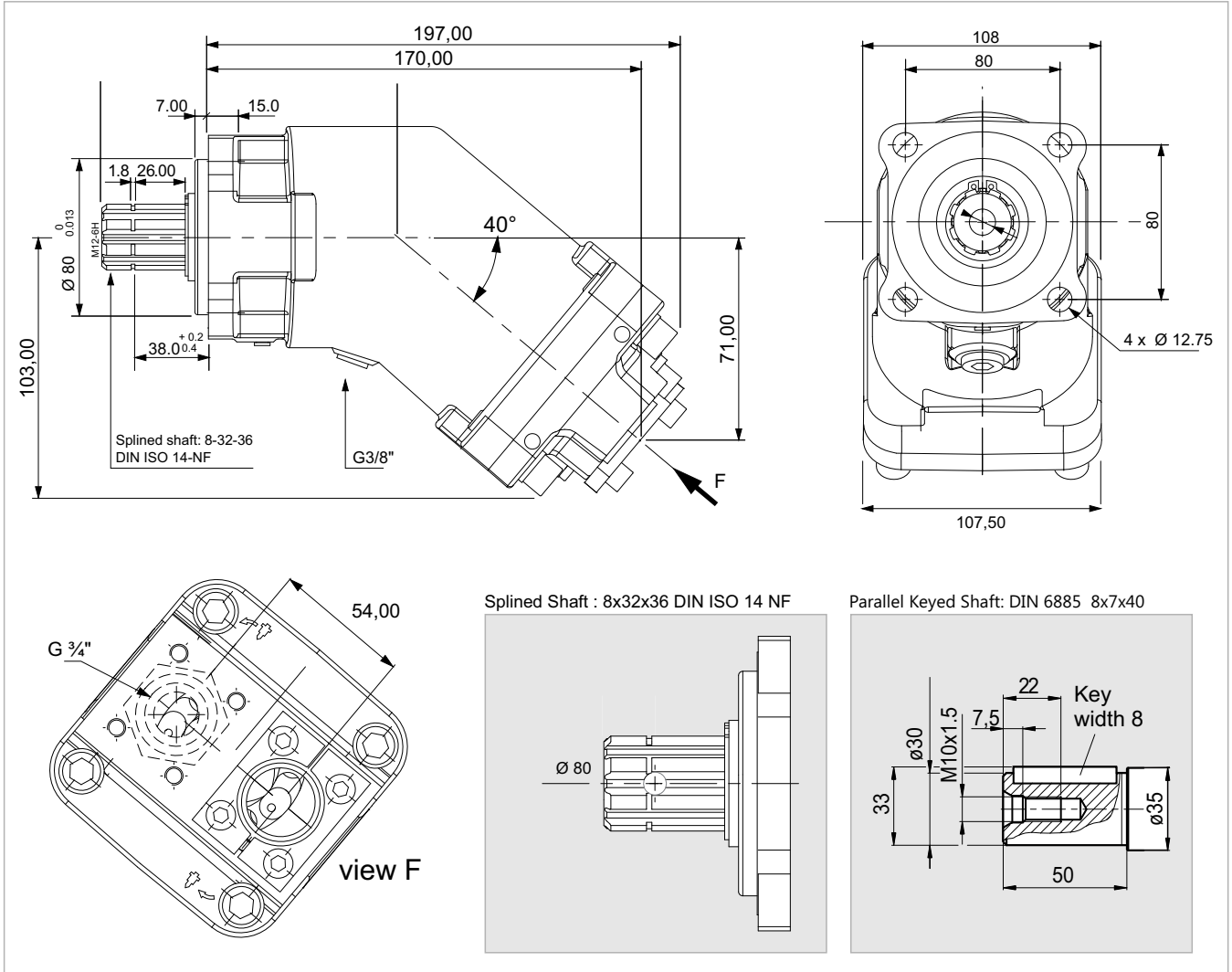

x 1000 rpm	25,00 cc
x 1500 rpm	37,50 cc
Max. Continuous Pump Speed	6250 rpm
Max. Intermittent Pump Speed	6800 rpm
Max. Continuous Pressure	400 bar
Max. Peak Pressure	450 bar
Torque bar	0.40 m.N/bar
Torque at 350 bar	140 m.N
Weight without accessories	10,00 kg
Weight with accessories	10,50 kg
Max. Motor Temperature	-25°
Min. Motor Temperature	110°

2PBM 32

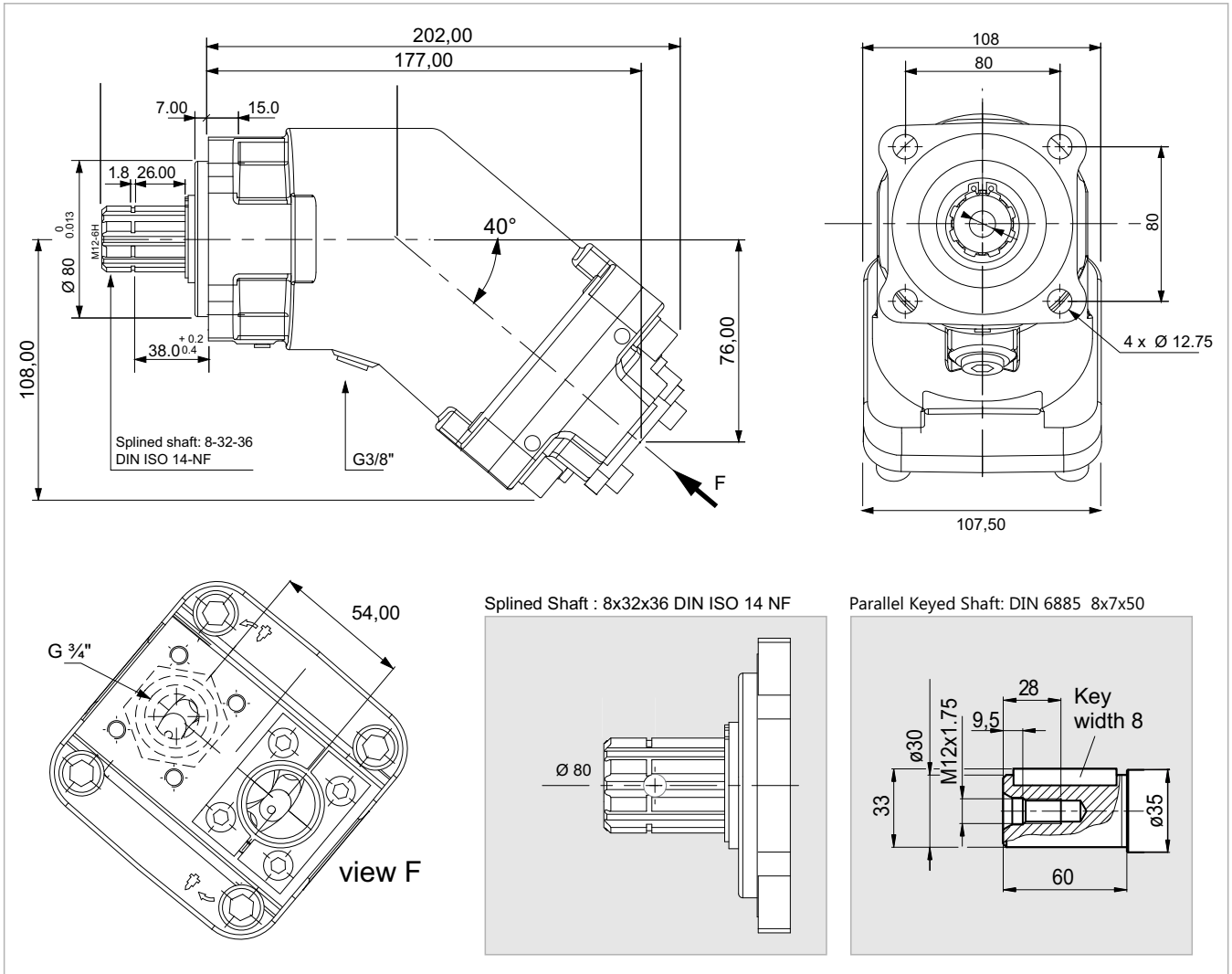

x 1000 rpm	32,00 cc
x 1500 rpm	48,00 cc
Max. Continuous Pump Speed	6250 rpm
Max. Intermittent Pump Speed	6800 rpm
Max. Continuous Pressure	400 bar
Max. Peak Pressure	450 bar
Torque bar	0.51 m.N/bar
Torque at 350 bar	174 m.N
Weight without accessories	11,00 kg
Weight with accessories	11,50 kg
Max. Motor Temperature	-25°
Min. Motor Temperature	110°

2PBM 40

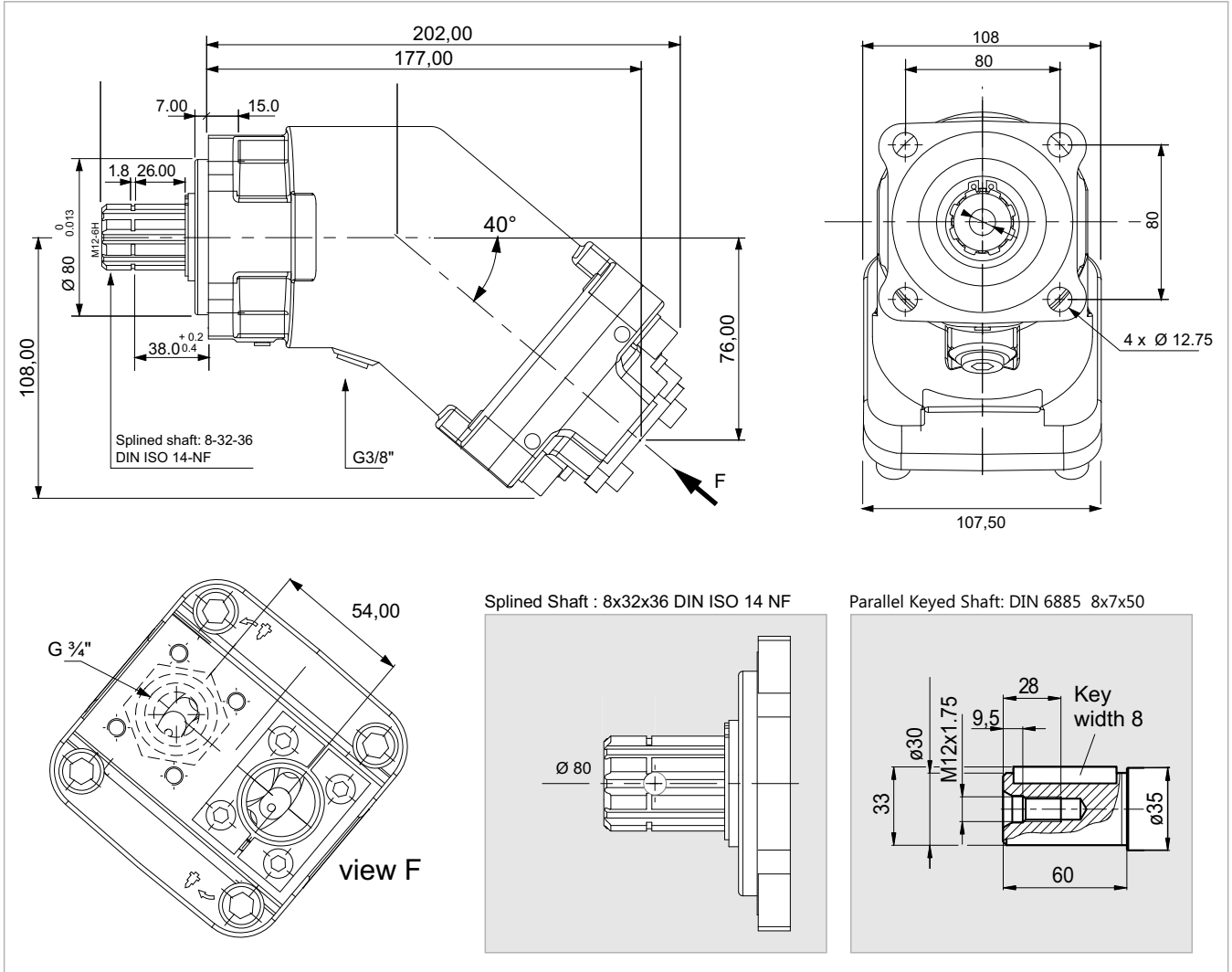

x 1000 rpm	40,20 cc
x 1500 rpm	60,30 cc
Max. Continuous Pump Speed	5600 rpm
Max. Intermittent Pump Speed	6300 rpm
Max. Continuous Pressure	400 bar
Max. Peak Pressure	450 bar
Torque bar	0.65 m.N/bar
Torque at 350 bar	228 m.N
Weight without accessories	11,00 kg
Weight with accessories	11,50 kg
Max. Motor Temperature	-25°
Min. Motor Temperature	110°

2PBM 50

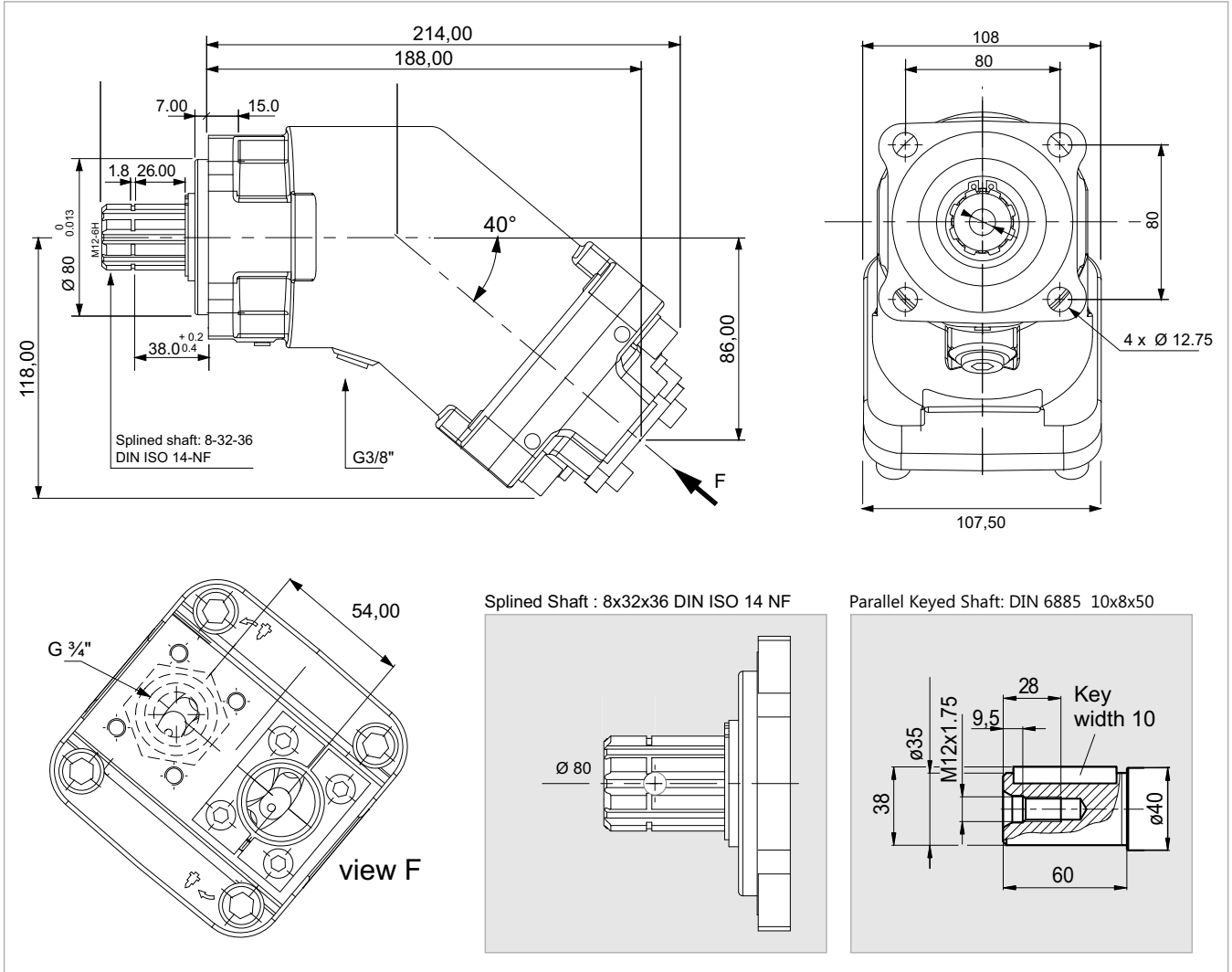

x 1000 rpm	50,00 cc
x 1500 rpm	75,00 cc
Max. Continuous Pump Speed	5000 rpm
Max. Intermittent Pump Speed	5500 rpm
Max. Continuous Pressure	400 bar
Max. Peak Pressure	450 bar
Torque bar	0.80 m.N/bar
Torque at 350 bar	280 m.N
Weight without accessories	11,00 kg
Weight with accessories	11,50 kg
Max. Motor Temperature	-25°
Min. Motor Temperature	110°

2PBM 56

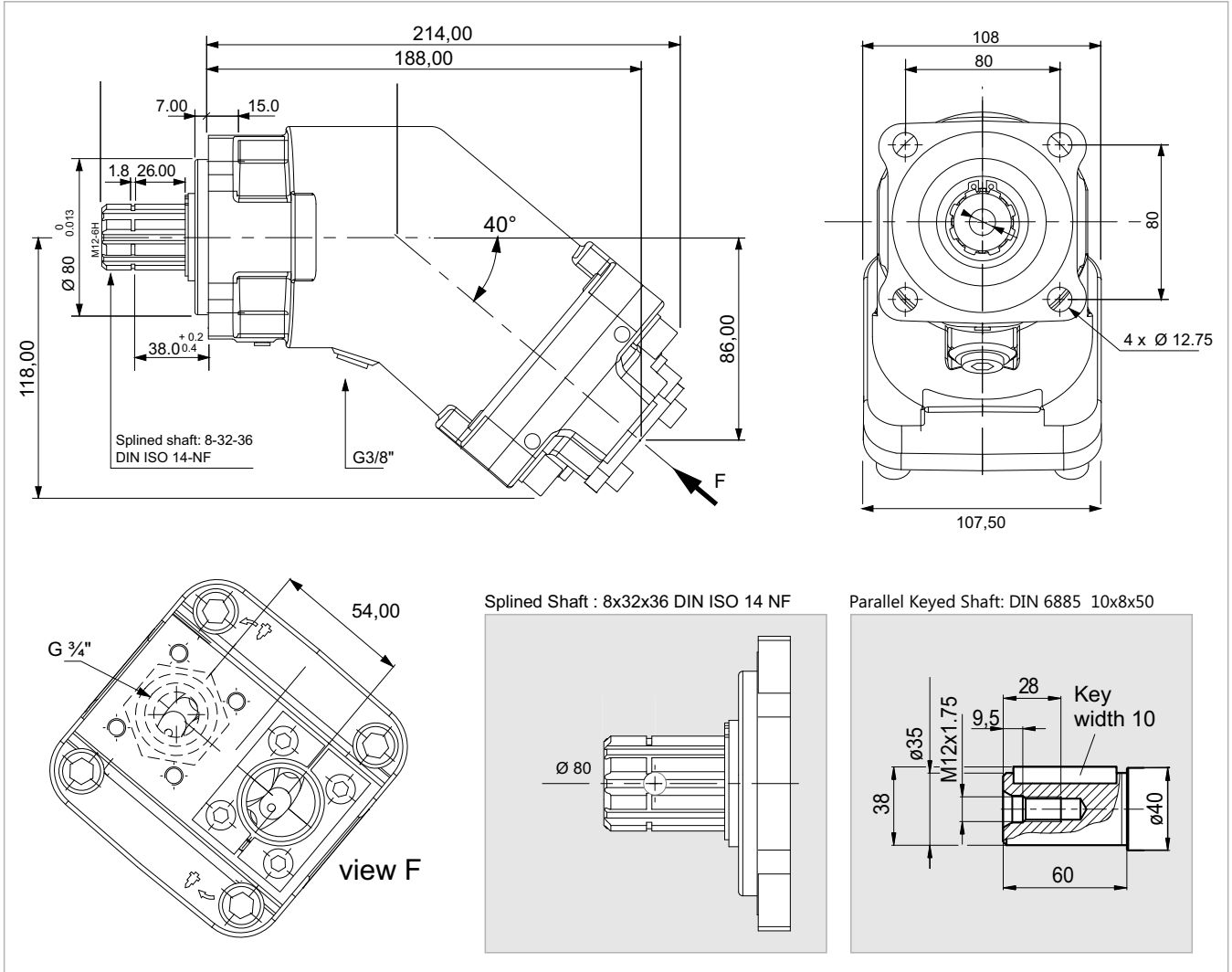

x 1000 rpm	56,40 cc
x 1500 rpm	84,60 cc
Max. Continuous Pump Speed	5000 rpm
Max. Intermittent Pump Speed	5500 rpm
Max. Continuous Pressure	400 bar
Max. Peak Pressure	450 bar
Torque bar	0.92 m.N/bar
Torque at 350 bar	320 m.N
Weight without accessories	12,00 kg
Weight with accessories	12,50 kg
Max. Motor Temperature	-25°
Min. Motor Temperature	110°

2PBM 63

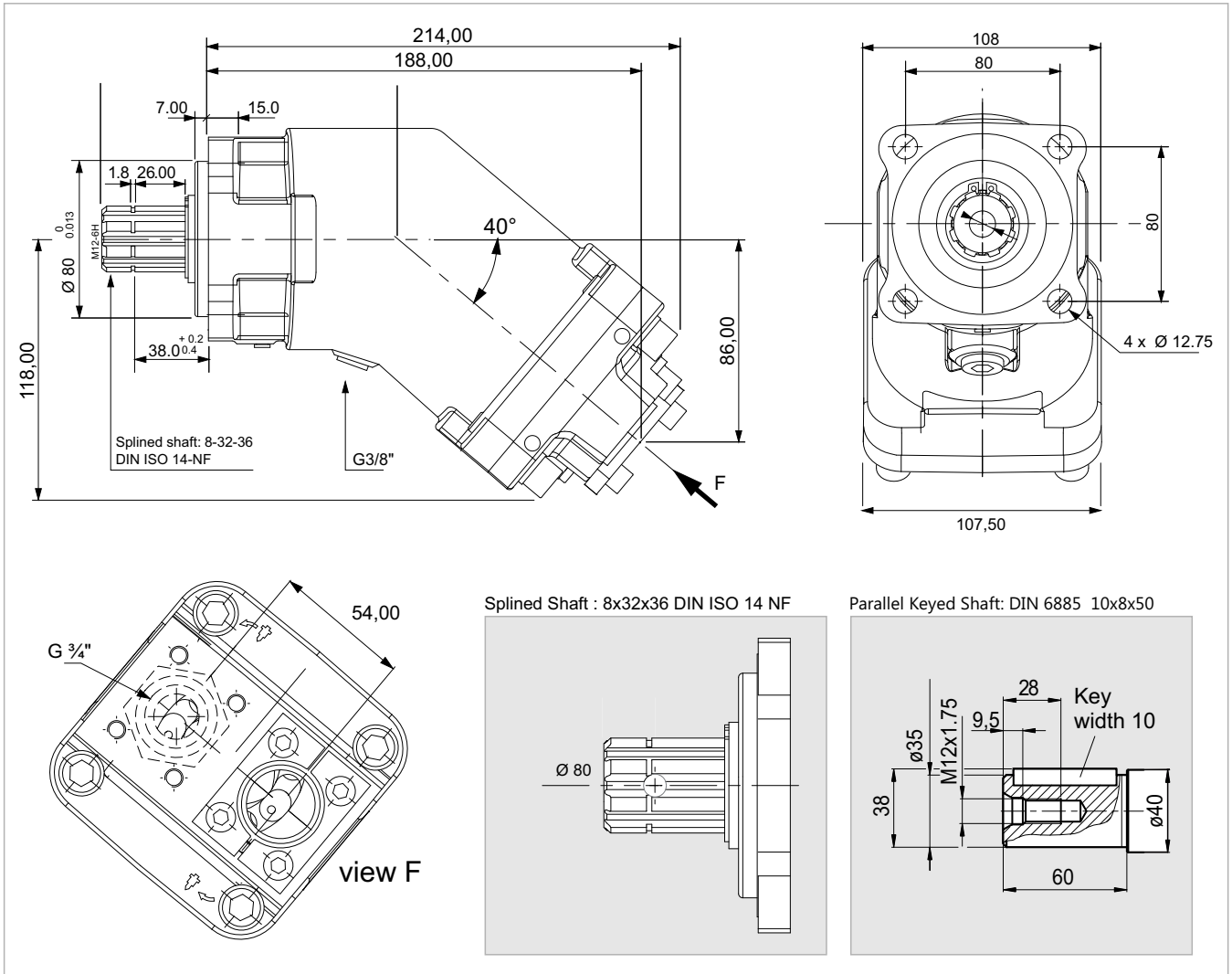

x 1000 rpm	63,00 cc
x 1500 rpm	94,50 cc
Max. Continuous Pump Speed	5000 rpm
Max. Intermittent Pump Speed	5500 rpm
Max. Continuous Pressure	400 bar
Max. Peak Pressure	450 bar
Torque bar	1.00 m.N/bar
Torque at 350 bar	350 m.N
Weight without accessories	12,00 kg
Weight with accessories	12,50 kg
Max. Motor Temperature	-25°
Min. Motor Temperature	110°

2PBM 80

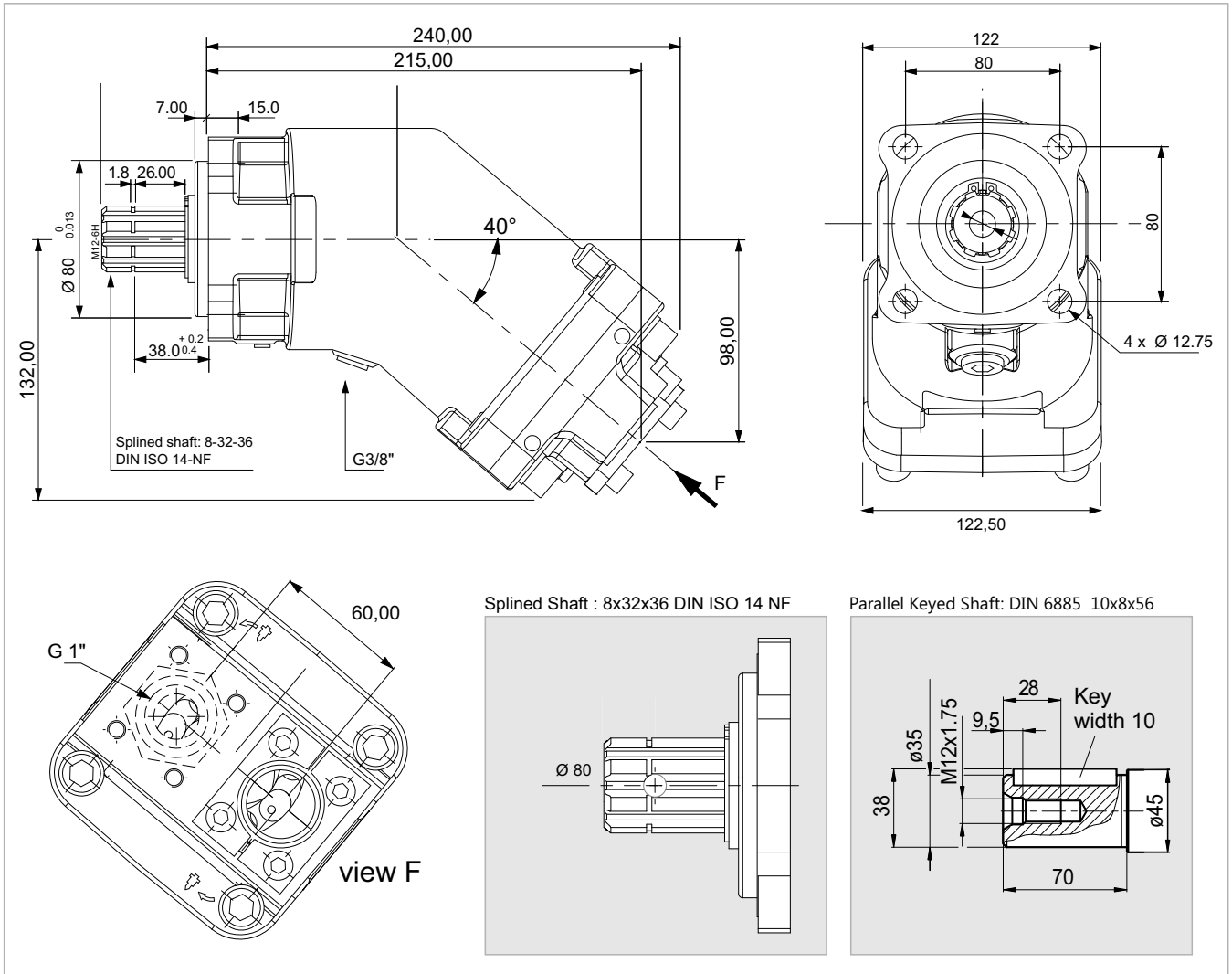

x 1000 rpm	80,00 cc
x 1500 rpm	120,00 cc
Max. Continuous Pump Speed	4400 rpm
Max. Intermittent Pump Speed	4900 rpm
Max. Continuous Pressure	400 bar
Max. Peak Pressure	450 bar
Torque bar	1.28 m.N/bar
Torque at 350 bar	440 m.N
Weight without accessories	15,00 kg
Weight with accessories	15,50 kg
Max. Motor Temperature	-25°
Min. Motor Temperature	110°

2PBM 108

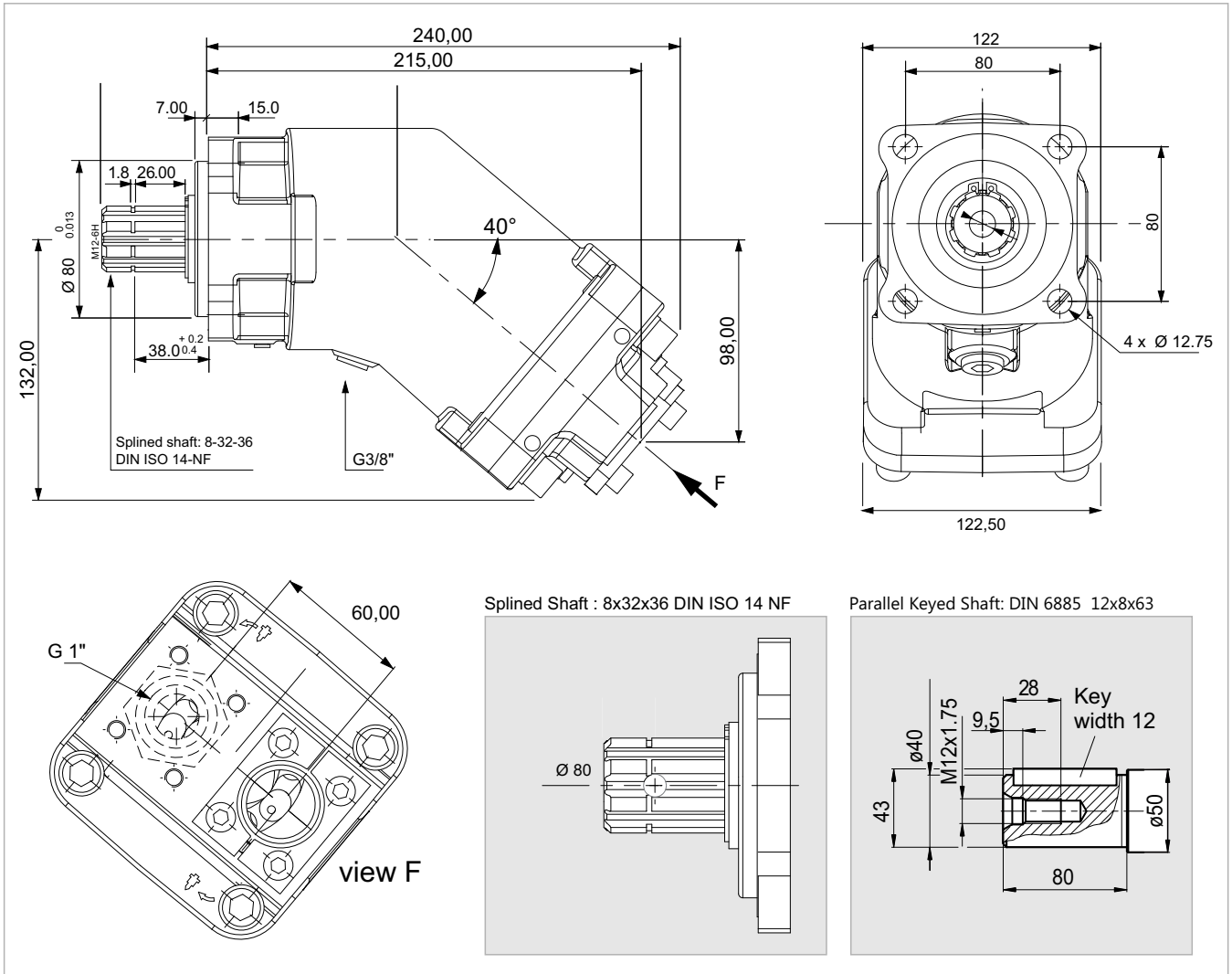

x 1000 rpm	108,40 cc
x 1500 rpm	162,60 cc
Max. Continuous Pump Speed	4000 rpm
Max. Intermittent Pump Speed	4400 rpm
Max. Continuous Pressure	400 bar
Max. Peak Pressure	450 bar
Torque bar	1.69 m.N/bar
Torque at 350 bar	600 m.N
Weight without accessories	16,00 kg
Weight with accessories	16,50 kg
Max. Motor Temperature	-25°
Min. Motor Temperature	110°

2PBM 130

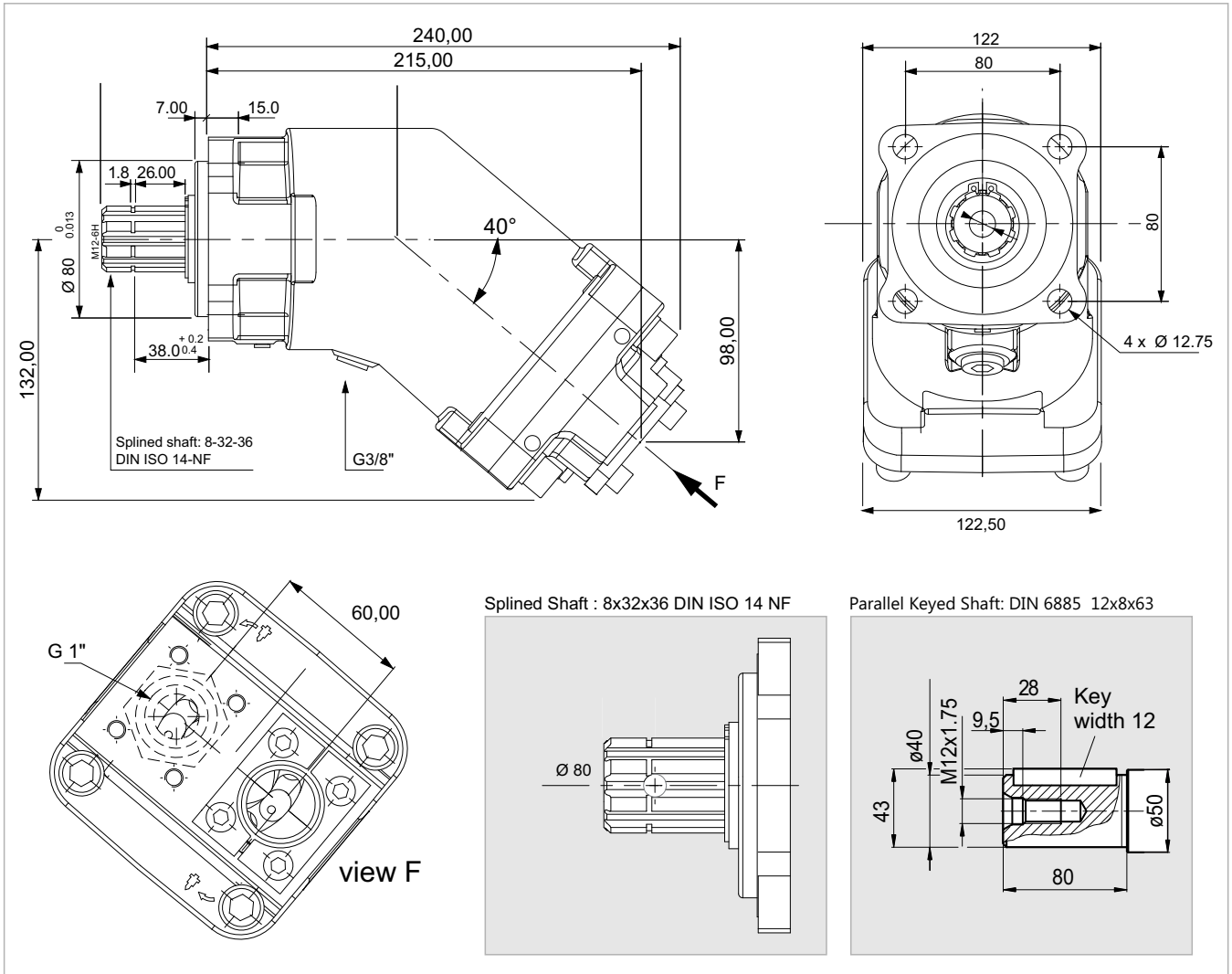

x 1000 rpm	130,00 cc
x 1500 rpm	195,00 cc
Max. Continuous Pump Speed	3400 rpm
Max. Intermittent Pump Speed	4400 rpm
Max. Continuous Pressure	400 bar
Max. Peak Pressure	450 bar
Torque bar	2.10 m.N/bar
Torque at 350 bar	710 m.N
Weight without accessories	16,50 kg
Weight with accessories	17,00 kg
Max. Motor Temperature	-25°
Min. Motor Temperature	110°

Direction of Rotation

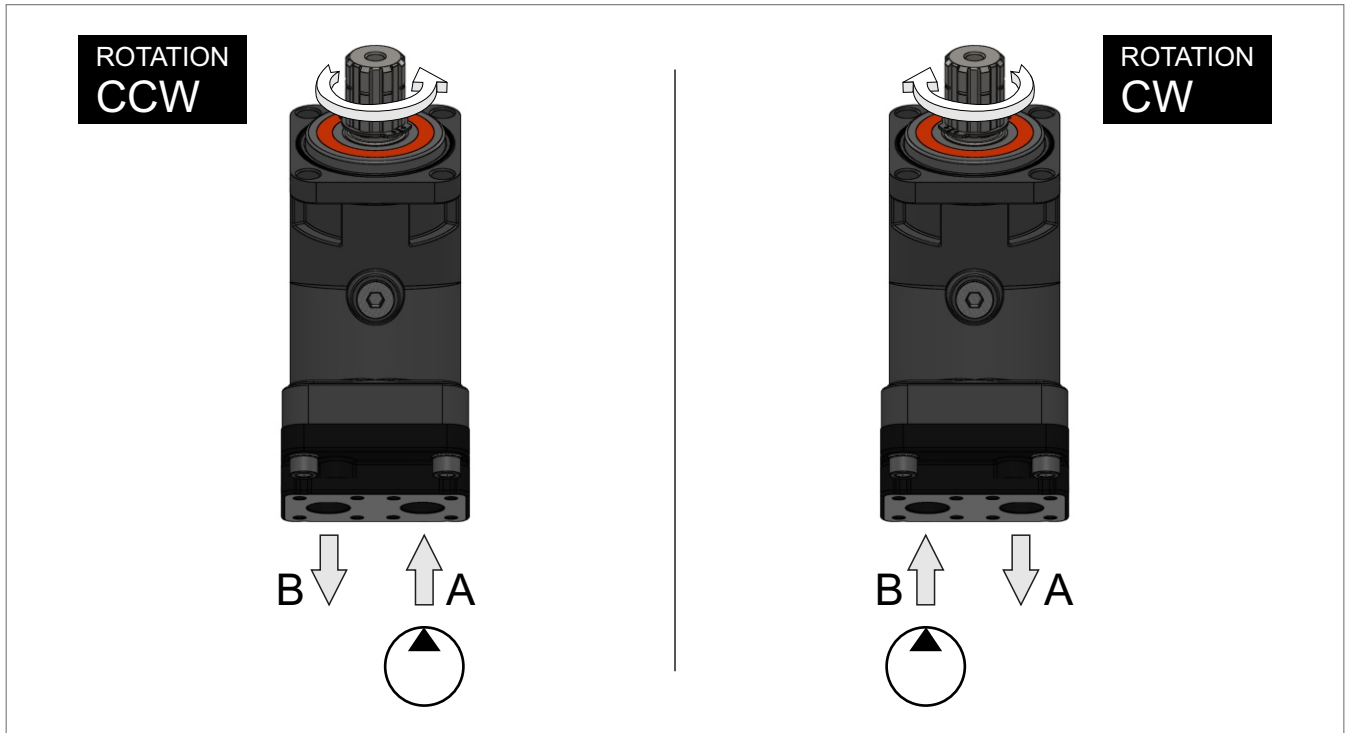

Quick Calculation

Flow rate

$$Q = \frac{V_s \cdot n}{1000 \eta_v} \text{ (lpm)}$$

Torque

$$M = \frac{V_s \cdot \Delta p \cdot \eta_{mh}}{63} \text{ (Nm)}$$

Power

$$P = \frac{2\pi \cdot M \cdot n}{60000} = \frac{M \cdot n}{9549} = \frac{Q \cdot \Delta p \cdot \eta_t}{600} \text{ (kw)}$$

Speed

$$n = \frac{1000 \cdot Q \cdot \eta_v}{V_s} \text{ (rpm)}$$

V_s = Displacement (ccm/rev.)

Δp = Diff. pressure (bar)

n = Speed (rpm)

Q = Flow (lpm)

η_v = Volumetric efficiency

η_{mh} = Mechanical-hydraulic efficiency

η_t = Total efficiency ($\eta_t = \eta_v \times \eta_{mh}$)

Address all questions regarding spare parts to your responsible Our Service Partner or the technical service department of the manufacture's plant / factory for the 2PBM Bent Axis Motors.

ÇELEBİ HİDROCEL OTOM. SAN. TİC. LTD. ŞTİ.

Fevziçakmak mh. Aslım Cd. No: 53 C Karatay / KONYA

Phone : +90 (332) 345 13 70 - +90 (332) 345 13 71

hidrocel@hidrocel.com.tr

Installation

POSITION

2PBM Motors can be operate any position.

DIRECTION OF ROTATION

2PBM Motors can be operate in both directions of rotation.

Before of Installation operation, the motor must be filled with hydraulic fluid and air bled.

INSTALLATION POSITION

See following examples.

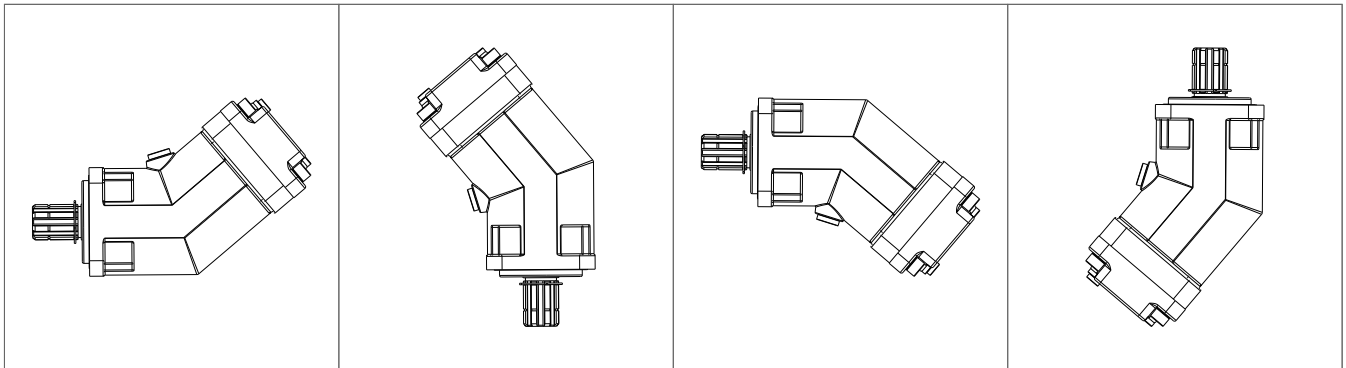

HYDRAULIC FLUID

Recommended ;

Generally : between 15 and 200 cSt.

Maximum : between 5 and 1600 cSt.

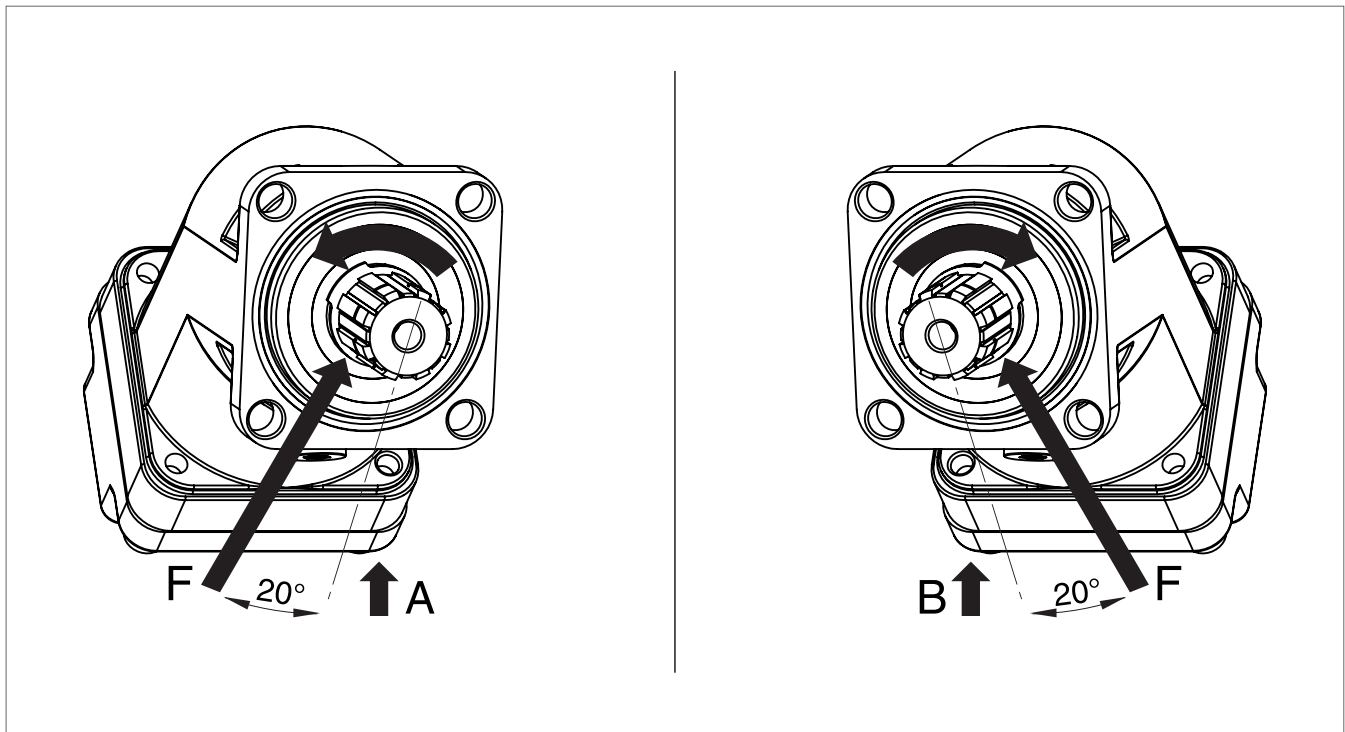

FOR USE;

Available via e-mail on request or each motor is supplied via Starting datasheet.

For detailed information about 2PBM Bent Axis Motors, please contact with Technical Department !!!

Complete Product Range

Piston Pumps

Piston Motors

DIN

DIN 5462 / ISO 14
8x32x35
8x32x36
DIN 6885



2PBA



2PBM

ISO

ISO 3019-2 (4 BOLTS)
DIN 5480 - W25,30,35,40,45
DIN 6885 - Ø20,25,30,35,40,45



2PS



2PM

SAE

SAE B2 C4 - SAE D
SAE J498b
SAE J 744



2PE



2PEM

M2

Fixed Plug-in

DIN 5480 / ISO 3019-2
W30 - W35 - W40
M21 - M22 - M23



2PMS

PA

DIN ISO 14
8x32x36

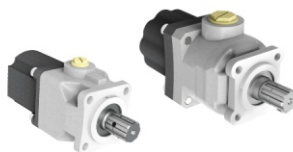

PA

PH

P2 Connection M8x125
Woodruff key 3x6,5 NF E
27-653 NF R 124-04
(2 BOLTS)

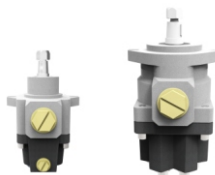

PH

Contact

ÇELEBİ HİDROCEL OTOM. SAN. TİC. LTD. ŞTİ.

Fevziçakmak mh. Aslım Cd.
No: 53 C Karatay / KONYA

Phone : +90 (332) 345 13 70

+90 (332) 345 13 71

Fax : +90 (332) 345 13 72

hidrocel@hidrocel.com.tr



www.hidrocel.com.tr